

FEATURES

- (1) 15.0"XGA display size for monitor
- (2) Color Gamut = 62% (to NTSC)
- (3) 8bit(6bit+FRC) Data Signal with LVDS interface system

TENTATIVE

MECHANICAL SPECIFICATIONS

Item	Specifications
Dimensional Outline (typ.)	336(W) x 249(H) x 13.5max(D) mm
Number of Pixels	1024(W) x 768(H) pixels
Active Area	304.128(W) x 228.096(H) mm
Pixel Pitch	0.297(W) x 0.297(H)
Weight (approximately)	1100g
Backlight	Twin CCFL, Sidelight type

ABSOLUTE MAXIMUM RATINGS

Item	Min.	Max.	Unit
Supply Voltage (V _{DD})	-0.3	4.0	V
(V _{FL})	0	2.0	kVrms
FL Driving Frequency (f _{FL})	-	100	kHz
Input Signal Voltage (V _{IN})	-0.3	V _{DD} +0.3	V
Operating Temperature	0	50	°C
Storage Temperature	-20	60	°C
Storage Humidity	10	90	%RH

ELECTRICAL SPECIFICATION

Item	Min.	Typ.	Max.	Unit	Remarks	
Supply Voltage	(V _{DD})	3.0	3.3	3.6	V	
	(V _{FL})	---	690	---	Vrms	I _{FL} =(6.0)mArms
FL Start Voltage (Ta=0°C)	1440	---	2000	Vrms		
Receiver Input Voltage	0	---	2.4	V		
Differential Input High Threshold(V _{TH})*1	---	---	(V _{OS})+0.1	V	V _{OS} = 1.2 V	
Differential Input Low Threshold(V _{TL})*1	(V _{OS})-0.1	---	---	V	V _{OS} = 1.2 V	
Current Consumption	*2 (I _{DD})	---	(430)	---	mA	
	*3 (I _{FL})	3.0	---	(6.0)	mArms	
*2 *3 Power Consumption (Target)	---	(10.5)	---	W	@200cd/m ²	

1 : Refer to DF90CF383/363* Specification by National Semiconductor Corporation.

This LCD module conforms to LVDS standard (TIA/EIA-644)

*2 : 8 color bars pattern

*3 : Excepting the efficiency FL inverter

OPTICAL SPECIFICATION (Ta=25°C)

Item	Min.	Typ.	Max.	Unit	Remarks
Contrast Ratio (CR)	100	250	---	---	
Viewing Angle (CR>=10)	(Upper+Lower)	80	90	---	deg.
	(Left+Right)	100	120	---	deg.
Response Time	(tr) L:10-90%	---	40	70	ms
	(tf) L: 90-10%	---	10	20	ms
Luminance	---	200	---	cd/m ²	I _{FL} =(6.0)mArms

*The information contained herein is presented only as a guide for the applications of our products. No responsibility is assumed by Toshiba or other rights of the third parties which may result from its use. No license is granted by implication or otherwise under any patent or patent rights of Toshiba or others.

*The information contained herein may be changed without prior notice. It is therefore advisable to contact Toshiba before proceeding with the design of equipment incorporating this product.

DIMENSIONAL OUTLINE

TENTATIVE

Unit : mm

Standard tolerance : 0.5

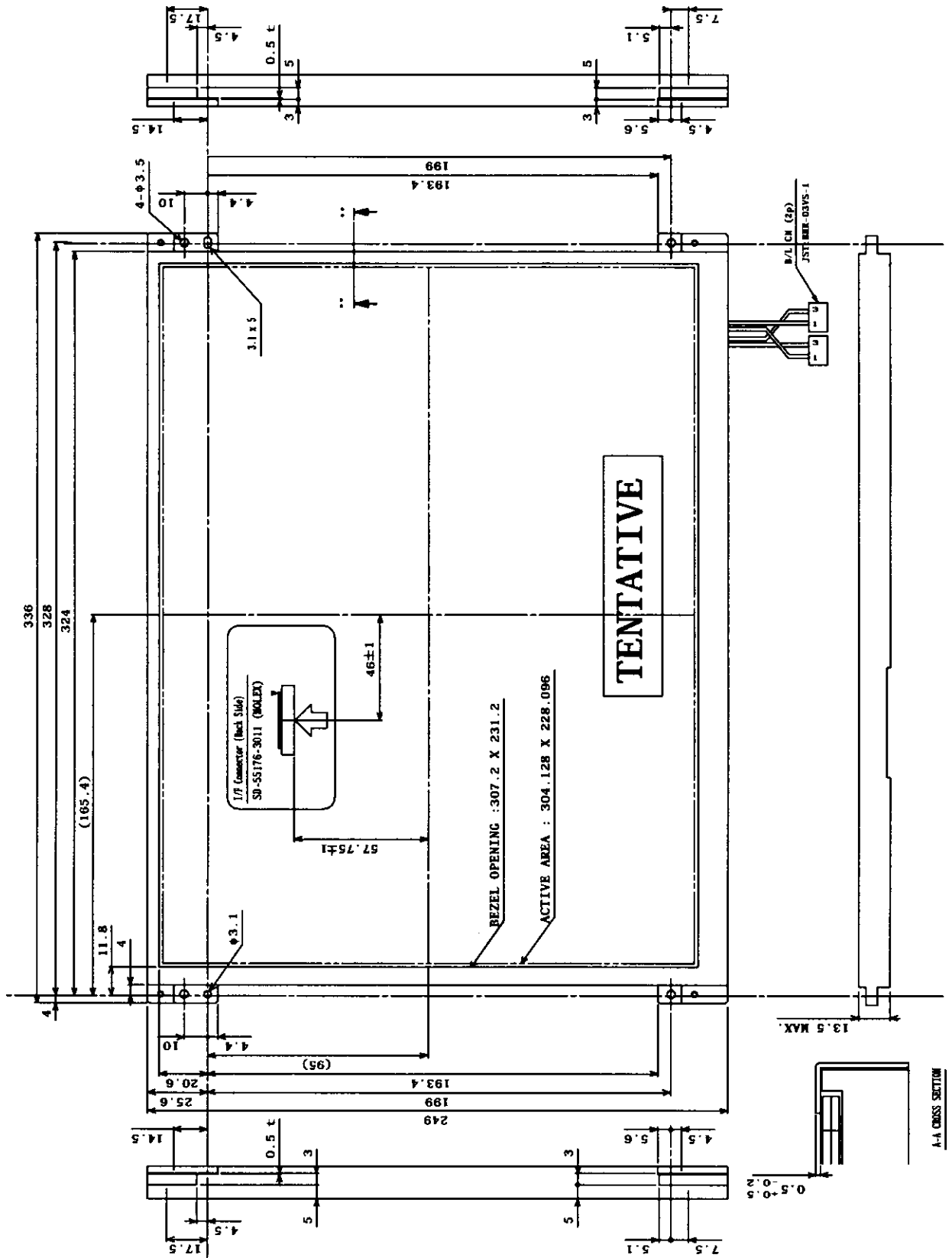

BLOCK DIAGRAM

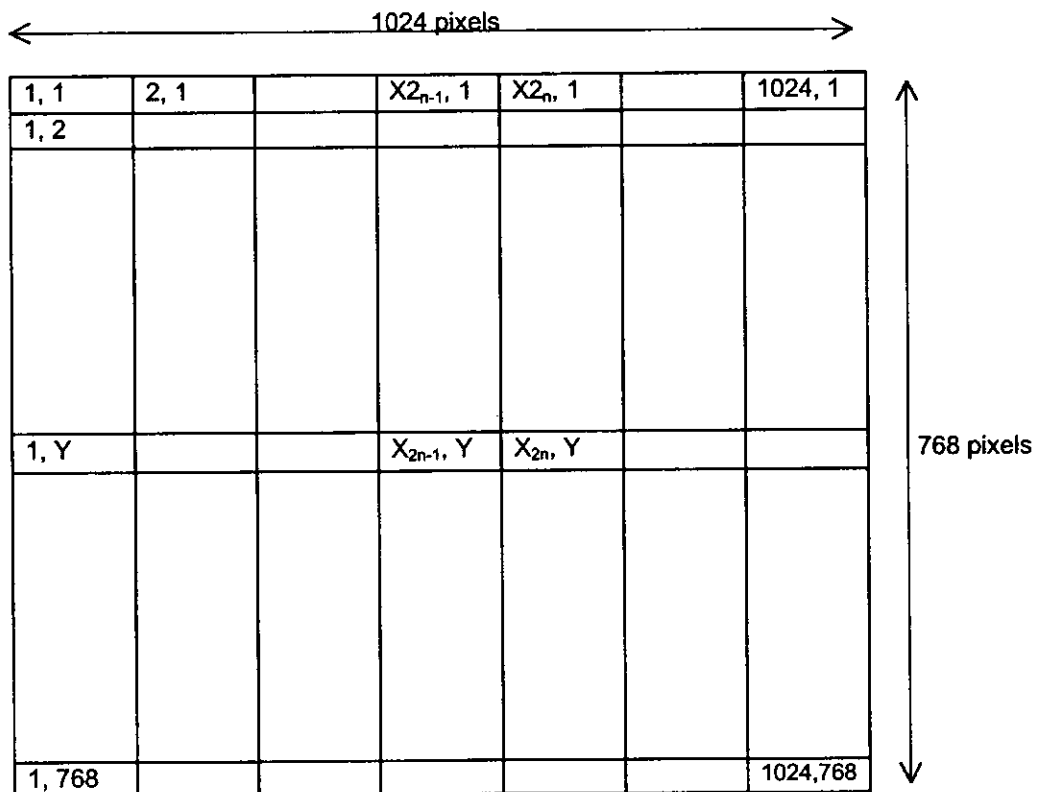
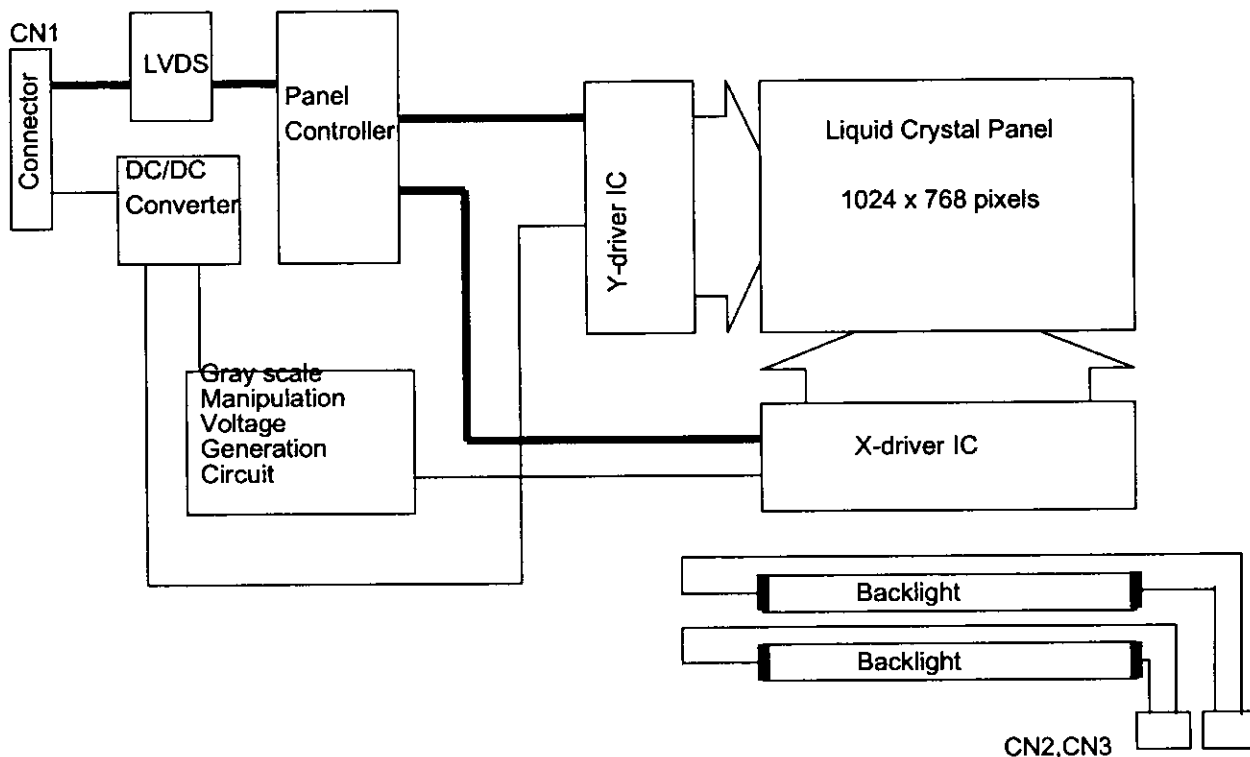

TIMING CHART

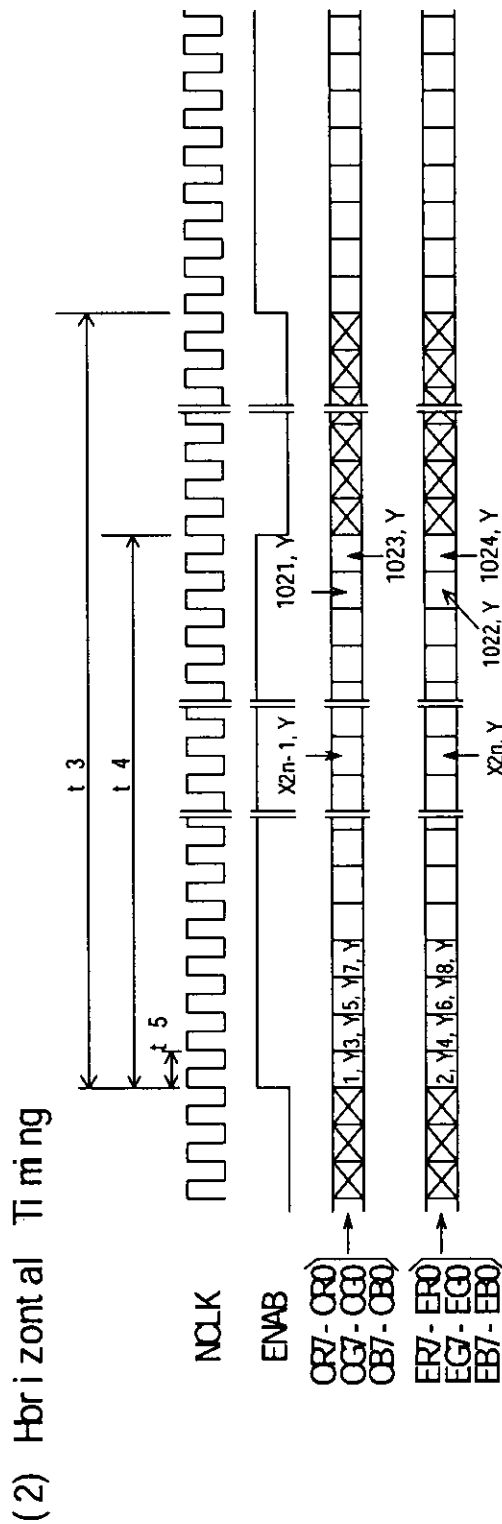
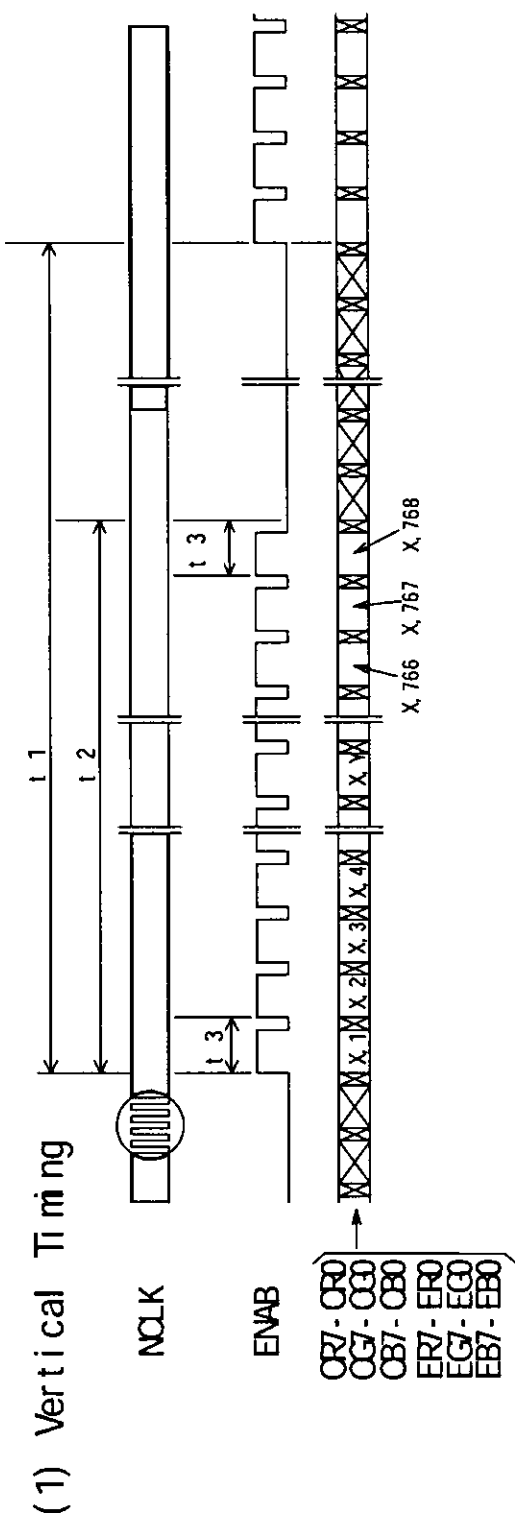

TIMING SPECIFICATION ^{1) 2) 3) 4) 5) 6)}

Item	Symbol	Min.	Frame Rate 75Hz	Frame Rate 70Hz	Frame Rate 60Hz	Max.	Unit	Remarks
Frame Period	t1	(778 x t3)	800 x t3	806 x t3	806 x t3	(990 x t3)	---	2) 6)
		---	13.33	14.27	16.67	TBD	ms	
Vertical Display Term	t2	768 x t3	768 x t3	768 x t3	768 x t3	768 x t3	---	2)
		---	12.79	13.60	15.88	---	ms	
Horizontal Scanning Time	t3	(654 x t5)	656 x t5	664 x t5	672 x t5	(870 x t5)	---	2) 6)
		---	16.66	17.70	20.68	---	μs	
Horizontal Display Term	t4	512 x t5	512 x t5	512 x t5	512 x t5	512 x t5	---	2)
		12.80	13.00	13.65	15.75	---	μs	
Clock Period	t5	25.0	25.40	26.67	30.77	TBD	ns	

Note 1) In case of using the long frame period, the deterioration of display quality, noise etc., may be occurred.

Note 2) Refer to TIMING CHART at page 4 and LVDS specification (DS90CF384A) by National Semiconductor Corporation.

Note 3) When ENAB is fixed to "H" level or "L" level after NCLK input, the panel is displayed as black. However, it may be occurred a flicker on the display.

Note 4) Do not fix NCLK to "H" or "L" level while the VDD (+3.3V) is supplied.

If NCLK is fixed to "H" level or "L" level for certain period while the VDD (+3.3V) is supplied, the panel may be damaged.

Note 5) Do not change t1 and t3 values in the operation. When t1 or t3 is changed, the panel is displayed as black.

Note 6) Please adjust LCD operating signal timing and FL driving frequency, to optimize the display quality. There is a possibility that flicker is observed by the interference of LCD operating signal timing and FL driving condition (especially driving frequency).

CONNECTOR PIN ASSIGNMENT FOR INTERFACE

CN1 INPUT SIGNAL

Connector : 55176-3011 (1.25mm) / MOLEX CO., LTD.

Mating Connector : 51146-3000 / MOLEX CO., LTD.

Terminal No.	Symbol	Function	
1	VDD	Power Supply : +3.3V	
2	VDD	Power Supply : +3.3V	
3	VDD	Power Supply : +3.3V	
4	GND		
5	GND		
6	R1IN0-	Transmission Data of Pixels 0 (Negative : -)	ODD
7	R1IN0+	Transmission Data of Pixels 0 (Positive : +)	ODD
8	R1IN1-	Transmission Data of Pixels 1 (Negative : -)	ODD
9	R1IN1+	Transmission Data of Pixels 1 (Positive : +)	ODD
10	R1IN2-	Transmission Data of Pixels 2 (Negative : -)	ODD
11	R1IN2+	Transmission Data of Pixels 2 (Positive : +)	ODD
12	R1CK-	Sampling Clock (Negative : -)	ODD
13	R1CK+	Sampling Clock (Positive : +)	ODD
14	R1IN3-	Transmission Data of Pixels 3 (Negative : -)	ODD
15	R1IN3+	Transmission Data of Pixels 3 (Positive : +)	ODD
16	GND		
17	R2IN0-	Transmission Data of Pixels 0 (Negative : -)	EVEN
18	R2IN0+	Transmission Data of Pixels 0 (Positive : +)	EVEN
19	R2IN1-	Transmission Data of Pixels 1 (Negative : -)	EVEN
20	R2IN1+	Transmission Data of Pixels 1 (Positive : +)	EVEN
21	R2IN2-	Transmission Data of Pixels 2 (Negative : -)	EVEN
22	R2IN2+	Transmission Data of Pixels 2 (Positive : +)	EVEN
23	R2CK-	Sampling Clock (Negative : -)	EVEN
24	R2CK+	Sampling Clock (Positive : +)	EVEN
25	R2IN3-	Transmission Data of Pixels 3 (Negative : -)	EVEN
26	R2IN3+	Transmission Data of Pixels 3 (Positive : +)	EVEN
27	GND		
28	NC		
29	SELLVDS	Select LVDS data order. See the following sheet.	
30	SELFRC	Select input signal bit (6bit/8bit). *H*Level: 8bit (FRC-ON) , *L*Level: 6bit(FRC-OFF)	

CN2.3 CCFL POWER SOURCE

Connector : BHR-03VS-1 / JAPAN SOLDERLESS TERMINAL MFG CO., LTD.

Mating Connector : SM02(8.0)B-BHS-1 / JAPAN SOLDERLESS TERMINAL MFG CO., LTD.

Terminal No.	Symbol	Function
1	VL	CCFL Power Supply (high voltage)
2	NC 1)	Non Connection (open)
3	GL	CCFL Power Supply (low voltage)

Note 1) NC terminal should be open.

FUNCTIONS

SETTING		SELLVDS	
		"L" level	"H" level
SELFRC	"H" level	8bit LVDS I/F 1 Refer to page 7,8	8bit LVDS I/F 2 Refer to page 9,10
	"L" level	6bit LVDS I/F Refer to page 11,12	Note 1)

Note 1) Do not set this mode (SELLVDS=H,SELFRC=L).

This mode (SELLVDS=H,SELFRC=L) is not supported.

RECOMMENDED TRANSMITTER TO LTM15C423S INTERFACE ASSIGNMENT

8bit Interface 1 : SELLVDS = L ,SELFRC=H

T1(Odd Pixels Data) Signal Interface					
Input Terminal		Input Signal(Graphics controller output signal)		Output Signal Symbol	To LTM15C423S Interface Terminal:Symbol
Number	Symbol	Symbol	Function		
51	T1IN0	OR0	RED Odd pixels DISPLAY DATA (LSB)	T1OUT0- T1OUT0+	6 7
52	T1IN1	OR1	RED Odd pixels DISPLAY DATA		
54	T1IN2	OR2	RED Odd pixels DISPLAY DATA		
55	T1IN3	OR3	RED Odd pixels DISPLAY DATA		
56	T1IN4	OR4	RED Odd pixels DISPLAY DATA		
3	T1IN6	OR5	RED Odd pixels DISPLAY DATA		
4	T1IN7	OG0	GREEN Odd pixels DISPLAY DATA (LSB)	T1OUT1- T1OUT1+	8 9
6	T1IN8	OG1	GREEN Odd pixels DISPLAY DATA		
7	T1IN9	OG2	GREEN Odd pixels DISPLAY DATA		
11	T1IN12	OG3	GREEN Odd pixels DISPLAY DATA		
12	T1IN13	OG4	GREEN Odd pixels DISPLAY DATA		
14	T1IN14	OG5	GREEN Odd pixels DISPLAY DATA		
15	T1IN15	OB0	BLUE Odd pixels DISPLAY DATA (LSB)	T1OUT2- T1OUT2+	10 11
19	T1IN18	OB1	BLUE Odd pixels DISPLAY DATA		
20	T1IN19	OB2	BLUE Odd pixels DISPLAY DATA		
22	T1IN20	OB3	BLUE Odd pixels DISPLAY DATA		
23	T1IN21	OB4	BLUE Odd pixels DISPLAY DATA		
24	T1IN22	OB5	BLUE Odd pixels DISPLAY DATA		
27	T1IN24	GND	1)	T1OUT3- T1OUT3+	14 15
28	T1IN25	GND	1)		
30	T1IN26	ENAB	COMPOUND SYNCHRONIZATION SIGNAL		
50	T1IN27	OR6	RED Odd pixels DISPLAY DATA		
2	T1IN5	OR7	RED Odd pixels DISPLAY DATA (MSB)		
8	T1IN10	OG6	GREEN Odd pixels DISPLAY DATA		
10	T1IN11	OG7	GREEN Odd pixels DISPLAY DATA (MSB)		
16	T1IN16	OB6	BLUE Odd pixels DISPLAY DATA		
18	T1IN17	OB7	BLUE Odd pixels DISPLAY DATA (MSB)		
25	T1IN23	GND	1)	T1CLK OUT- T1CLK OUT+	12 13
31	T1CLK IN	NCLK	DATA SAMPLING CLOCK		

Type No. of transmitters (made by National Semiconductor Corporation)
DS90C*383* series

- 1) It is highly recommended to connect this terminal with GND line.
LCD controller is NC (non connection.)

RECOMMENDED TRANSMITTER TO LTM15C423S INTERFACE ASSIGNMENT

8bit Interface 1 : SELVDS = L ,SELFRC=H

T2(Even Pixels Data)		Signal Interface		Output Signal Symbol	To LTM15C423S Interface Terminal:Symbol
Input Terminal Number	Symbol	Input Signal(Symbol)	(Graphics controller output signal) Function		
51	T2IN0	ER0	RED Even pixels DISPLAY DATA (LSB)	T2OUT0- T2OUT0+	17 18
52	T2IN1	ER1	RED Even pixels DISPLAY DATA		
54	T2IN2	ER2	RED Even pixels DISPLAY DATA		
55	T2IN3	ER3	RED Even pixels DISPLAY DATA		
56	T2IN4	ER4	RED Even pixels DISPLAY DATA		
3	T2IN6	ER5	RED Even pixels DISPLAY DATA		
4	T2IN7	EG0	GREEN Even pixels DISPLAY DATA (LSB)	T2OUT1- T2OUT1+	19 20
6	T2IN8	EG1	GREEN Even pixels DISPLAY DATA		
7	T2IN9	EG2	GREEN Even pixels DISPLAY DATA		
11	T2IN12	EG3	GREEN Even pixels DISPLAY DATA		
12	T2IN13	EG4	GREEN Even pixels DISPLAY DATA		
14	T2IN14	EG5	GREEN Even pixels DISPLAY DATA		
15	T2IN15	EB0	BLUE Even pixels DISPLAY DATA (LSB)	T2OUT2- T2OUT2+	21 22
19	T2IN18	EB1	BLUE Even pixels DISPLAY DATA		
20	T2IN19	EB2	BLUE Even pixels DISPLAY DATA		
22	T2IN20	EB3	BLUE Even pixels DISPLAY DATA		
23	T2IN21	EB4	BLUE Even pixels DISPLAY DATA		
24	T2IN22	EB5	BLUE Even pixels DISPLAY DATA		
27	T2IN24	GND	1)	T2OUT3- T2OUT3+	25 26
28	T2IN25	GND	1)		
30	T2IN26	GND	1)		
50	T2IN27	ER6	RED Even pixels DISPLAY DATA		
2	T2IN5	ER7	RED Even pixels DISPLAY DATA (MSB)		
8	T2IN10	EG6	GREEN Even pixels DISPLAY DATA		
10	T2IN11	EG7	GREEN Even pixels DISPLAY DATA (MSB)	T2CLK OUT- T2CLK OUT+	23 24
16	T2IN16	EB6	BLUE Even pixels DISPLAY DATA		
18	T2IN17	EB7	BLUE Even pixels DISPLAY DATA (MSB)		
25	T2IN23	GND	1)		
31	T2CLK IN	NCLK	DATA SAMPLING CLOCK		

Type No. of transmitters (made by National Semiconductor Corporation)
DS90C*383* series

- 1) It is highly recommended to connect this terminal with GND line.
LCD controller is NC (non connection.)

RECOMMENDED TRANSMITTER TO LTM15C423S INTERFACE ASSIGNMENT

8bit Interface 2 : SELLVDS = H ,SELFRC=H
--

T1(Odd Pixels Data) Signal Interface					
Input Terminal		Input Signal(Graphics controller output signal)		Output Signal Symbol	To LTM15C423S Interface Terminal:Symbol
Number	Symbol	Symbol	Function		
51	T1IN0	OR2	RED Odd pixels DISPLAY DATA	T1OUT0- T1OUT0+	6 7
52	T1IN1	OR3	RED Odd pixels DISPLAY DATA		
54	T1IN2	OR4	RED Odd pixels DISPLAY DATA		
55	T1IN3	OR5	RED Odd pixels DISPLAY DATA		
56	T1IN4	OR6	RED Odd pixels DISPLAY DATA		
3	T1IN6	OR7	RED Odd pixels DISPLAY DATA (MSB)		
4	T1IN7	OG2	GREEN Odd pixels DISPLAY DATA		
6	T1IN8	OG3	GREEN Odd pixels DISPLAY DATA	T1OUT1- T1OUT1+	8 9
7	T1IN9	OG4	GREEN Odd pixels DISPLAY DATA		
11	T1IN12	OG5	GREEN Odd pixels DISPLAY DATA		
12	T1IN13	OG6	GREEN Odd pixels DISPLAY DATA		
14	T1IN14	OG7	GREEN Odd pixels DISPLAY DATA (MSB)		
15	T1IN15	OB2	BLUE Odd pixels DISPLAY DATA		
19	T1IN18	OB3	BLUE Odd pixels DISPLAY DATA		
20	T1IN19	OB4	BLUE Odd pixels DISPLAY DATA	T1OUT2- T1OUT2+	10 11
22	T1IN20	OB5	BLUE Odd pixels DISPLAY DATA		
23	T1IN21	OB6	BLUE Odd pixels DISPLAY DATA		
24	T1IN22	OB7	BLUE Odd pixels DISPLAY DATA (MSB)		
27	T1IN24	GND	1)		
28	T1IN25	GND	1)		
30	T1IN26	ENAB	COMPOUND SYNCHRONIZATION SIGNAL		
50	T1IN27	OR0	RED Odd pixels DISPLAY DATA (LSB)	T1OUT3- T1OUT3+	14 15
2	T1IN5	OR1	RED Odd pixels DISPLAY DATA		
8	T1IN10	OG0	GREEN Odd pixels DISPLAY DATA (LSB)		
10	T1IN11	OG1	GREEN Odd pixels DISPLAY DATA		
16	T1IN16	OB0	BLUE Odd pixels DISPLAY DATA (LSB)		
18	T1IN17	OB1	BLUE Odd pixels DISPLAY DATA		
25	T1IN23	GND	1)		
31	T1CLK IN	NCLK	DATA SAMPLING CLOCK	T1CLK OUT- T1CLK OUT+	12 13

Type No. of transmitters (made by National Semiconductor Corporation)
DS90C*383* series

- 1) It is highly recommended to connect this terminal with GND line.
LCD controller is NC (non connection.)

RECOMMENDED TRANSMITTER TO LTM15C423S INTERFACE ASSIGNMENT

8bit Interface 2 : SELLVDS = H ,SELFRC=H

T2(Even Pixels Data)		Signal Interface			Output Signal Symbol	To LTM15C423S Interface Terminal:Symbol
Input Terminal Number	Symbol	Input Signal(Symbol)	Graphics controller output signal Function	Output Signal Symbol		
51	T2IN0	ER2	RED Even pixels DISPLAY DATA	T2OUT0- T2OUT0+	17 18	
52	T2IN1	ER3	RED Even pixels DISPLAY DATA			
54	T2IN2	ER4	RED Even pixels DISPLAY DATA			
55	T2IN3	ER5	RED Even pixels DISPLAY DATA			
56	T2IN4	ER6	RED Even pixels DISPLAY DATA			
3	T2IN6	ER7	RED Even pixels DISPLAY DATA (MSB)			
4	T2IN7	EG2	GREEN Even pixels DISPLAY DATA	T2OUT1- T2OUT1+	19 20	
6	T2IN8	EG3	GREEN Even pixels DISPLAY DATA			
7	T2IN9	EG4	GREEN Even pixels DISPLAY DATA			
11	T2IN12	EG5	GREEN Even pixels DISPLAY DATA			
12	T2IN13	EG6	GREEN Even pixels DISPLAY DATA			
14	T2IN14	EG7	GREEN Even pixels DISPLAY DATA (MSB)			
15	T2IN15	EB2	BLUE Even pixels DISPLAY DATA	T2OUT2- T2OUT2+	21 22	
19	T2IN18	EB3	BLUE Even pixels DISPLAY DATA			
20	T2IN19	EB4	BLUE Even pixels DISPLAY DATA			
22	T2IN20	EB5	BLUE Even pixels DISPLAY DATA			
23	T2IN21	EB6	BLUE Even pixels DISPLAY DATA			
24	T2IN22	EB7	BLUE Even pixels DISPLAY DATA (MSB)			
27	T2IN24	GND	1)	T2OUT3- T2OUT3+	25 26	
28	T2IN25	GND	1)			
30	T2IN26	GND	1)			
50	T2IN27	ER0	RED Even pixels DISPLAY DATA (LSB)			
2	T2IN5	ER1	RED Even pixels DISPLAY DATA			
8	T2IN10	EG0	GREEN Even pixels DISPLAY DATA (LSB)			
10	T2IN11	EG1	GREEN Even pixels DISPLAY DATA	T2CLK OUT- T2CLK OUT+	23 24	
16	T2IN16	EB0	BLUE Even pixels DISPLAY DATA (LSB)			
18	T2IN17	EB1	BLUE Even pixels DISPLAY DATA			
25	T2IN23	GND	1)			
31	T2CLK IN	NCLK	DATA SAMPLING CLOCK			

Type No. of transmitters (made by National Semiconductor Corporation)
DS90C*383* series

1) It is highly recommended to connect this terminal with GND line.

LCD controller is NC (non connection.)

RECOMMENDED TRANSMITTER TO LTM15C423S INTERFACE ASSIGNMENT

6bit Interface : SELVDS = L ,SELFRC=L

T1(Odd Pixels Data) Signal Interface					
Input Terminal		Input Signal(Graphics controller output signal)		Output Signal Symbol	To LTM15C423S Interface Terminal:Symbol
Number	Symbol	Symbol	Function		
44	T1IN0	OR0	RED Odd pixels DISPLAY DATA (LSB)	T1OUT0- T1OUT0+	6 7
45	T1IN1	OR1	RED Odd pixels DISPLAY DATA		
47	T1IN2	OR2	RED Odd pixels DISPLAY DATA		
48	T1IN3	OR3	RED Odd pixels DISPLAY DATA		
1	T1IN4	OR4	RED Odd pixels DISPLAY DATA		
3	T1IN5	OR5	RED Odd pixels DISPLAY DATA (MSB)		
4	T1IN6	OG0	GREEN Odd pixels DISPLAY DATA (LSB)	T1OUT1- T1OUT1+	8 9
6	T1IN7	OG1	GREEN Odd pixels DISPLAY DATA		
7	T1IN8	OG2	GREEN Odd pixels DISPLAY DATA		
9	T1IN9	OG3	GREEN Odd pixels DISPLAY DATA		
10	T1IN10	OG4	GREEN Odd pixels DISPLAY DATA		
12	T1IN11	OG5	GREEN Odd pixels DISPLAY DATA (MSB)		
13	T1IN12	OB0	BLUE Odd pixels DISPLAY DATA (LSB)	T1OUT2- T1OUT2+	10 11
15	T1IN13	OB1	BLUE Odd pixels DISPLAY DATA		
16	T1IN14	OB2	BLUE Odd pixels DISPLAY DATA		
18	T1IN15	OB3	BLUE Odd pixels DISPLAY DATA		
19	T1IN16	OB4	BLUE Odd pixels DISPLAY DATA		
20	T1IN17	OB5	BLUE Odd pixels DISPLAY DATA (MSB)		
22	T1IN18	GND	1)	T1CLK OUT- T1CLK OUT+	12 13
23	T1IN19	GND	1)		
25	T1IN20	ENAB	COMPOUND SYNCHRONIZATION SIGNAL		
26	T1CLK IN	NCLK	DATA SAMPLING CLOCK		

Type No. of transmitters (made by National Semiconductor Corporation)
DS90C*363* series

- 1) It is highly recommended to connect this terminal with GND line.
LCD controller is NC (non connection.)
- 2) It is highly recommended to connects the terminal No.14&15 with GND line.

RECOMMENDED TRANSMITTER TO LTM15C423S INTERFACE ASSIGNMENT

6bit Interface 1 : SELLVDS = L ,SELFRC=L
--

T2(Even Pixels Data)		Signal Interface		Output Signal Symbol	To LTM15C423S Interface Terminal:Symbol
Input Terminal Number	Symbol	Input Signal Symbol	Graphics controller output signal Function		
44	T2IN0	ER0	RED Even pixels DISPLAY DATA (LSB)	T2OUT0- T2OUT0+	17 18
45	T2IN1	ER1	RED Even pixels DISPLAY DATA		
47	T2IN2	ER2	RED Even pixels DISPLAY DATA		
48	T2IN3	ER3	RED Even pixels DISPLAY DATA		
1	T2IN4	ER4	RED Even pixels DISPLAY DATA		
3	T2IN5	ER5	RED Even pixels DISPLAY DATA (MSB)	T2OUT1- T2OUT1+	19 20
4	T2IN6	EG0	GREEN Even pixels DISPLAY DATA (LSB)		
6	T2IN7	EG1	GREEN Even pixels DISPLAY DATA		
7	T2IN8	EG2	GREEN Even pixels DISPLAY DATA		
9	T2IN9	EG3	GREEN Even pixels DISPLAY DATA		
10	T2IN10	EG4	GREEN Even pixels DISPLAY DATA	T2OUT2- T2OUT2+	21 22
12	T2IN11	EG5	GREEN Even pixels DISPLAY DATA (MSB)		
13	T2IN12	EB0	BLUE Even pixels DISPLAY DATA (LSB)		
15	T2IN13	EB1	BLUE Even pixels DISPLAY DATA		
16	T2IN14	EB2	BLUE Even pixels DISPLAY DATA		
18	T2IN15	EB3	BLUE Even pixels DISPLAY DATA	T2CLK OUT- T2CLK OUT+	23 24
19	T2IN16	EB4	BLUE Even pixels DISPLAY DATA		
20	T2IN17	EB5	BLUE Even pixels DISPLAY DATA (MSB)		
22	T2IN18	GND	1)		
23	T2IN19	GND	1)		
25	T2IN20	GND	1)		
26	T2CLK IN	NCLK	DATA SAMPLING CLOCK		

Type No. of transmitters (made by National Semiconductor Corporation)
DS90C*363* series

- 1) It is highly recommended to connect this terminal with GND line.
LCD controller is NC (non connection.)
- 2) It is highly recommended to connects the terminal No.25&26 with GND line.

COLORS COMBINATION TABLE

8bit Interface

	Display	R7 R6 R5 R4 R3 R2 R1 R0	G7 G6 G5 G4 G3 G2 G1 G0	B7 B6 B5 B4 B3 B2 B1 B0	Gray Scale Level
Basic Color	Black	L L L L L L L L	L L L L L L L L	L L L L L L L L	-
	Blue	L L L L L L L L	L L L L L L L L	H H H H H H H H	-
	Green	L L L L L L L L	H H H H H H H H	L L L L L L L L	-
	Light Blue	L L L L L L L L	H H H H H H H H	H H H H H H H H	-
	Red	H H H H H H H H	L L L L L L L L	L L L L L L L L	-
	Purple	H H H H H H H H	L L L L L L L L	H H H H H H H H	-
	Yellow	H H H H H H H H	H H H H H H H H	L L L L L L L L	-
	White	H H H H H H H H	H H H H H H H H	H H H H H H H H	-
Gray Scale of Red	Black	L L L L L L L L	L L L L L L L L	L L L L L L L L	L 0
	Dark ↑ ↓ Light	L L L L L L L H	L L L L L L L L	L L L L L L L L	L 0
		L L L L L L H H	L L L L L L L L	L L L L L L L L	L 0
		L L L L L H L L	L L L L L L L L	L L L L L L L L	L 4
		:	:	:	L5...
		:	:	:	L252
		H H H H H H L H	L L L L L L L L	L L L L L L L L	L253
	H H H H H H H L	L L L L L L L L	L L L L L L L L	L254	
	H H H H H H H H	L L L L L L L L	L L L L L L L L	Red L255	
	Black	L L L L L L L L	L L L L L L L L	L L L L L L L L	L 0
Dark ↑ ↓ Light	L L L L L L L L	L L L L L L L H	L L L L L L L L	L 0	
	L L L L L L L L	L L L L L L H H	L L L L L L L L	L 0	
	L L L L L L L L	L L L L L H L L	L L L L L L L L	L 4	
	:	:	:	L5...	
	:	:	:	L252	
	L L L L L L L L	H H H H H H L H	L L L L L L L L	L253	
	L L L L L L L L	H H H H H H H L	L L L L L L L L	L254	
	L L L L L L L L	H H H H H H H H	L L L L L L L L	Green L255	
Black	L L L L L L L L	L L L L L L L L	L L L L L L L L	L 0	
Dark ↑ ↓ Light	L L L L L L L L	L L L L L L L H	L L L L L L L H	L 0	
	L L L L L L L L	L L L L L L L H	L L L L L L H H	L 0	
	L L L L L L L L	L L L L L L L L	L L L L L H L L	L 4	
	:	:	:	L5...	
	:	:	:	L252	
	L L L L L L L L	L L L L L L L L	H H H H H H L H	L243	
	L L L L L L L L	L L L L L L L L	H H H H H H H L	L254	
	L L L L L L L L	L L L L L L L L	H H H H H H H H	Blue L255	
Black	L L L L L L L L	L L L L L L L L	L L L L L L L L	L 0	
Dark ↑ ↓ Light	L L L L L L L H	L L L L L L L H	L L L L L L L H	L 0	
	L L L L L L H L	L L L L L L H L	L L L L L L H L	L 0	
	L L L L L L H H	L L L L L L H H	L L L L L L H H	L 0	
	L L L L L H L L	L L L L L H L L	L L L L L H L L	L 4	
	:	:	:	L5...	
	:	:	:	L252	
	H H H H H H L H	H H H H H H L H	H H H H H H L H	L253	
	H H H H H H H L	H H H H H H H L	H H H H H H H L	L254	
White	H H H H H H H H	H H H H H H H H	H H H H H H H H	White L255	

COLORS COMBINATION TABLE

6bit Interface

	Display	MSB						LSB						Gray Scale Level						
		R5	R4	R3	R2	R1	R0	G5	G4	G3	G2	G1	G0		B5	B4	B3	B2	B1	B0
Basic Color	Black	L	L	L	L	L	L	L	L	L	L	L	L	L	L	L	L	L	L	-
	Blue	L	L	L	L	L	L	L	L	L	L	L	L	H	H	H	H	H	H	-
	Green	L	L	L	L	L	L	H	H	H	H	H	H	L	L	L	L	L	L	-
	Light Blue	L	L	L	L	L	L	H	H	H	H	H	H	H	H	H	H	H	H	-
	Red	H	H	H	H	H	H	L	L	L	L	L	L	L	L	L	L	L	L	-
	Purple	H	H	H	H	H	H	L	L	L	L	L	L	H	H	H	H	H	H	-
	Yellow	H	H	H	H	H	H	H	H	H	H	H	H	L	L	L	L	L	L	-
White	H	H	H	H	H	H	H	H	H	H	H	H	H	H	H	H	H	H	-	
Gray Scale of Red	Black	L	L	L	L	L	L	L	L	L	L	L	L	L	L	L	L	L	L	L 0
	Dark ↑ ↓ Light	L	L	L	L	L	H	L	L	L	L	L	L	L	L	L	L	L	L	L 1
		L	L	L	L	H	L	L	L	L	L	L	L	L	L	L	L	L	L	L 2
		:	:	:	:	:	:	:	:	:	:	:	:	:	:	:	:	:	:	L3... L60
		H	H	H	H	L	H	L	L	L	L	L	L	L	L	L	L	L	L	L61
		H	H	H	H	H	L	L	L	L	L	L	L	L	L	L	L	L	L	L62
	H	H	H	H	H	H	L	L	L	L	L	L	L	L	L	L	L	L	Red L63	
Gray Scale of Green	Black	L	L	L	L	L	L	L	L	L	L	L	L	L	L	L	L	L	L	L 0
	Dark ↑ ↓ Light	L	L	L	L	L	L	L	L	L	L	L	H	L	L	L	L	L	L	L 1
		L	L	L	L	L	L	L	L	L	L	H	L	L	L	L	L	L	L	L 2
		:	:	:	:	:	:	:	:	:	:	:	:	:	:	:	:	:	:	L3... L60
		L	L	L	L	L	L	H	H	H	H	L	H	L	L	L	L	L	L	L61
		L	L	L	L	L	L	H	H	H	H	H	L	L	L	L	L	L	L	L62
	L	L	L	L	L	L	H	H	H	H	H	H	L	L	L	L	L	L	Green L63	
Gray Scale of Blue	Black	L	L	L	L	L	L	L	L	L	L	L	L	L	L	L	L	L	L	L 0
	Dark ↑ ↓ Light	L	L	L	L	L	L	L	L	L	L	L	L	L	L	L	L	L	H	L 1
		L	L	L	L	L	L	L	L	L	L	L	L	L	L	L	L	H	L	L 2
		:	:	:	:	:	:	:	:	:	:	:	:	:	:	:	:	:	:	L3... L60
		L	L	L	L	L	L	L	L	L	L	L	L	H	H	H	H	L	H	L61
		L	L	L	L	L	L	L	L	L	L	L	L	H	H	H	H	H	L	L62
	L	L	L	L	L	L	L	L	L	L	L	L	H	H	H	H	H	H	Blue L63	
Gray Scale of White & Black	Black	L	L	L	L	L	L	L	L	L	L	L	L	L	L	L	L	L	L	L 0
	Dark ↑ ↓ Light	L	L	L	L	L	H	L	L	L	L	L	H	L	L	L	L	L	H	L 1
		L	L	L	L	H	L	L	L	L	L	H	L	L	L	L	L	H	L	L 2
		:	:	:	:	:	:	:	:	:	:	:	:	:	:	:	:	:	:	L3... L60
		H	H	H	H	L	H	H	H	H	H	L	H	H	H	H	H	L	H	L61
		H	H	H	H	H	L	H	H	H	H	H	L	H	H	H	H	H	L	L62
	H	H	H	H	H	H	H	H	H	H	H	H	H	H	H	H	H	H	White L63	

**FOR SAFETY**

LCD module is generally designed with precise parts to achieve light weighted thin mechanical dimensions. In using our Modules, make certain that you fully understand and put into practice the warnings and safety precautions detailed in Engineering Information No.EE-N001, "CAUTIONS AND INSTRUCTIONS FOR TOSHIBA LCD MODULES". Refer to individual specifications and TECHNICAL DATA sheets (hereinafter called "TD") for more detailed technical information.

1) SPECIAL PURPOSES

- A) Toshiba's Standard LCD Modules have not been customized for operation in extreme environments or for use in applications where performance failures could be life-threatening or otherwise catastrophic.
- B) Since Toshiba's Standard LCD Modules have not been designed for operation in extreme environments, they must never be used in devices that will be exposed to abnormally high levels of vibration or shock which exceed Toshiba's published specification limits.
- C) In addition, since Toshiba Standard LCD Modules have not been designed for use in applications where performance failures could be life-threatening or catastrophic, they must never be installed in aircraft navigation control systems (such as, but not limited to Traffic Collision Avoidance System and Air Traffic Indicator), in military defense or weapons systems, in critical industrial process-control systems (e.g., those involved in the production of nuclear energy), or in critical medical device or patient life-support systems.

2) DISASSEMBLING OR MODIFICATION

DO NOT DISASSEMBLE OR MODIFY the module. It may damage sensitive parts inside LCD module, and may cause scratches or dust on the display. Toshiba does not warrant the module, if customer disassembled or modified it.

3) BREAKAGE OF LCD PANEL

DO NOT INGEST liquid crystal material, DO NOT INHALE this material, and DO NOT CONTACT the material with skin, if LCD panel is broken and liquid crystal material spills out.
If liquid crystal material comes into mouth or eyes, rinse mouth or eyes out with water immediately.
If this material contact with skin or cloths, wash it off immediately with alcohol and rinse thoroughly with water.

4) GLASS OF LCD PANEL

BE CAREFUL WITH CHIPS OF GLASS that may cause injuring fingers or skin, when the glass is broken.

5) ELECTRIC SHOCK

DISCONNECT POWER SUPPLY before handling LCD module.
DO NOT TOUCH the parts inside LCD module and the fluorescent lamp's connector or cables in order to prevent electric shock, because high voltage is supplied to these parts from the inverter unit while power supply is turned on.

6) ABSOLUTE MAXIMUM RATINGS AND POWER PROTECTION CIRCUIT

DO NOT EXCEED the absolute maximum rating values under the worst probable conditions caused by the supply voltage variation, input voltage variation, variation in parts' constants, environmental temperature, etc., otherwise LCD module may be damaged.
Employ protection circuit for power supply, whenever the specification or TD specifies it.
Suitable protection circuit should be applied for each system design.

7) DISPOSAL

When dispose LCD module, obey to the applicable environmental regulations.