

HITACHI

Displays, Hitachi, Ltd.

DATE: Sep. 5, 2000

Hitachi Electronic Devices (USA), Inc.

CUSTOMER'S ACCEPTANCE SPECIFICATIONS

TX31D30VC1CAA

CONTENTS

No.	Item	Sheet No.	Page
—	COVER	3284PS 2601-TX31D30VC1CAA-1	1-1/1
—	—	—	—
—	DESCRIPTION	3284PS 2603-TX31D30VC1CAA-1	3-1/1
1	ABSOLUTE MAXIMUM RATINGS	3284PS 2604-TX31D30VC1CAA-1	4-1/1
2	OPTICAL CHARACTERISTICS	3284PS 2605-TX31D30VC1CAA-1	5-1/2 , 2/2
3	ELECTRICAL CHARACTERISTICS	3284PS 2606-TX31D30VC1CAA-1	6-1/1
4	BLOCK DIAGRAM	3284PS 2607-TX31D30VC1CAA-1	7-1/1
5	INTERFACE PIN CONNECTION	3284PS 2608-TX31D30VC1CAA-1	8-1/2 , 2/2
6	INTERFACE TIMING	3284PS 2609-TX31D30VC1CAA-1	9-1/3 - 3/3
7	DIMENSIONAL OUTLINE	3284PS 2610-TX31D30VC1CAA-1	10-1/2 , 2/2
8	DESIGNATION OF LOT MARK	3284PS 2611-TX31D30VC1CAA-1	11-1/1
9	COSMETIC SPECIFICATIONS	3284PS 2612-TX31D30VC1CAA-1	12-1/3 - 3/3
10	PRECAUTION	3284PS 2613-TX31D30VC1CAA-1	13-1/3 - 3/3

Accepted by : _____

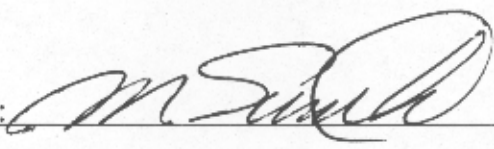
Proposed by :  _____

DESCRIPTION

The specifications are applied to the following TFT Liquid Crystal Display Module with Back-light unit.

Note : Inverter device for Back-Light is not built in so it should be prepared by yourself.

General Specifications

Type Name	TX31D30VC1CAA	
Effective Display Area	H 246 × V 184.5	[mm]
Display Dots	H (800×3)×V 600	[dots]
(Display Pixels)	(H 800× V 600)	[pixels]
Pixel Pitch	H 0.3075 × V 0.3075	
Color Pixel Arrangement	R·G·B Vertical Stripe	
Display Mode	Transmissive Mode, Normally White Mode	
Number of Colors	262k	[colors]
Viewing Angle	6:00 Direction	
Dimensions Outline	H 280.0(typ.)× V 205.5(typ.)× t 12.5(max.)	[mm]
Weight	Approximately 720	[g]

1. ABSOLUTE MAXIMUM RATINGS

1.1 ENVIRONMENTAL ABSOLUTE MAXIMUM RATINGS

Item	Operation		Non-operation		Unit	Note
	Min.	Max.	Min.	Max.		
Temperature	0	50	-20	60	°C	1)
Humidity	2)		2)		%RH	1)
Vibration	—	4.9 (0.5G)	—	19.6 (2G)	m/s ²	3)
Shock	—	29.4 (3G)	—	294 (30G)	m/s ²	4)
Corrosive Gas	Not Acceptable.		Not Acceptable			
Illumination at LCD Surface	—	50,000	—	50,000	lx	

- Notes
- 1) Environmental temperature and humidity of this unit, not of system installed with this unit.
At low temperature the brightness of CFL drop and the life time of CFL become to be short.
 - 2) Ambient temp. $T_a \leq 40\text{ }^\circ\text{C}$: 85 % RH Max. Without condensation.
 $T_a > 40\text{ }^\circ\text{C}$: Absolute humidity must be lower than the humidity of 85 % RH at 40 °C.
Without condensation.
 - 3) Frequency of the vibration shall be between 20 Hz and 50 Hz. (except resonance point)
 - 4) Pulse width of the shock shall be 7 ms.

1.2 ELECTRICAL ABSOLUTE MAXIMUM RATINGS

(1) TFT LIQUID CRYSTAL DISPLAY MODULE

VSS=0V

Item	Symbol	Min.	Max.	Unit	Note
Power Supply Voltage for logic	VDD	0	4.3	V	
Input signal Voltage for logic	VI	-0.2	VDD+0.2	V	1)
Electrostatic Durability	VESD0	± 100		V	2), 3)
	VESD1	± 8		kV	2), 4)

- Notes
- 1) The specification shall be applied to pixel data signal and clock signal.
 - 2) Discharge circuit to be connected : 200 pF - 250 Ω, Environmental : 25°C - 70 % RH
 - 3) The specification shall be applied to I/F connector pins.
 - 4) The specification shall be applied to the surface of both a metal bezel and a LCD panel.

(2) BACK-LIGHT UNIT

GND=0V

Item	Symbol	Min.	Max.	Unit	Note
Lamp Current	IL	-	13.5	mA _{rms}	1)
Lamp Voltage	VL	-	2000	V _{rms}	2)

- Notes
- 1) The specification shall be applied to CFL unit. (A CFL unit consists of two pieces of CFLs.)
 - 2) The specification shall be applied at connector pins for back-light units at start-up.

2. OPTICAL CHARACTERISTICS

The following optical characteristics shall be measured during operation of the unit (TFT-LCD module and Back-Light) on the condition the measuring systems operation are stable. It takes about 30 minutes. The measured point shall be at the center of the LCD unless any specified. The ambient light excluding light from the backlight unit of the module shall be prohibited.

• Measuring equipment : Pritchard 1980A, or equivalent

Temperature of LCD = 25 °C, VDD = 3.3 V, fV = 60 Hz, IL= 12.0mA

Item	Symbol	Conditions	Min.	Typ.	Max.	Unit	Note	
Contrast Ratio	CR	$\theta = 0^\circ$ 1)	150	(350)	—		2)	
Response Time	RISE		tr	—	30	—	ms	3)
	FALL		tf	—	20	—	ms	3)
Brightness (White)	Bwh		240	300	—	cd/m ²		
Brightness Uniformity	Buni		70	—	—	%	4)	
Color Position on CIE	Red		x	—	0.57	—	—	
			y	—	0.33	—		
	Green		x	—	0.31	—		
			y	—	0.54	—		
	Blue		x	—	0.15	—		
			y	—	0.13	—		
	White		x	—	0.32	—		
			y	—	0.33	—		

Notes 1) Definition of Viewing Angle

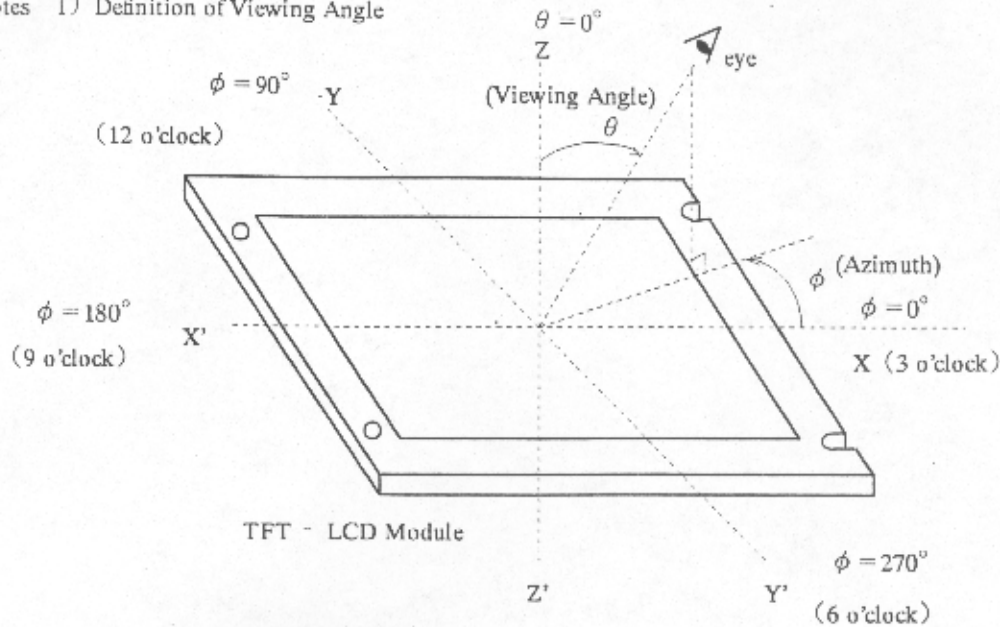

2) Definition of Contrast Ratio(CR):

$$CR = \frac{\text{(Luminance at displaying WHITE)}}{\text{(Luminance at displaying BLACK)}}$$

3) Definition of Response Time

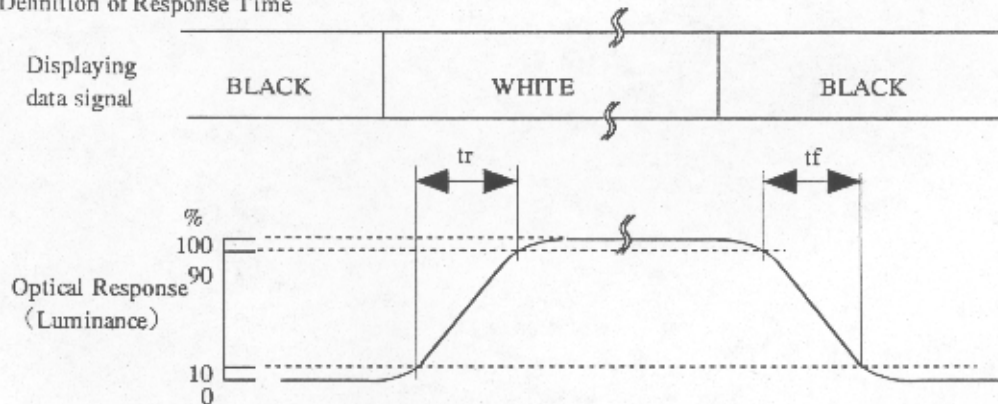

4) Definition of Brightness Uniformity

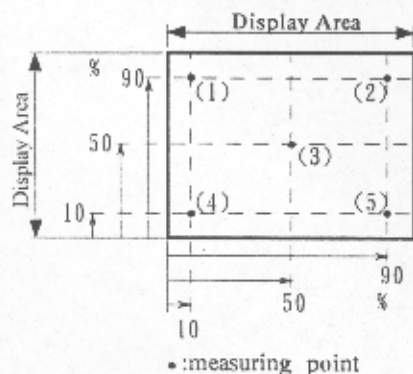

The brightness uniformity (Buni) is defined as the following equation.

$$Buni = \frac{Bmin}{Bmax} \times 100$$

where, Bmax = Maximum brightness among 5 measuring points
 Bmin = Minimum brightness among 5 measuring points

3. ELECTRICAL CHARACTERISTICS

3.1 TFT LIQUIDO CRYSTAL DISPLAY MODULE

Ta=25°C, VSS=0V

Item	Symbol	Min.	Typ.	Max.	Unit	Note
Power Supply Voltage	VDD	3	3.3	3.6	V	
Input Voltage for Logic Circuits	Hi	V _{IH}	—	VDD	V	1)
	Lo	V _{IL}	VSS	0.8	V	1)
Power Supply Current	I _{DD}	—	190	270	mA	2), 3)
VSYNC Frequency	f _V	55	60	65	Hz	
HSYNC Frequency	f _H	—	37.5	39.2	kHz	
DCLK Frequency	f _{CLK}	—	38.4	40	MHz	

- Notes
- 1) Display data pins and Timing signal pins are subjected.
 - 2) f_V = 60Hz, f_{CLK} = 38.4 MHz, VDD = 3.3V, DC Current.
 - 3) Current capacity for VDD power source should be large than 3A.

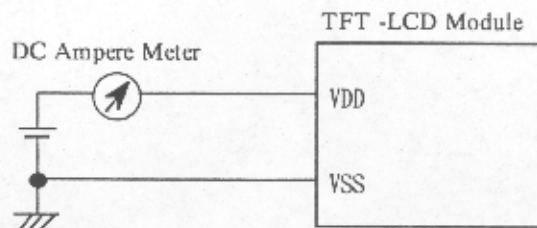

- Typical value is measured when displaying Black raster.
 Maximum is measured when displaying Vertical-stripe pattern.
 3) Current capacity for VDD power source should be large than 3A.

3.2 BACK-LIGHT UNIT

Ta = 25°C

Item	Symbol	Min.	Typ.	Max.	Unit	Note
Lamp Current	I _L	6.5	—	13.0	mA _{rms}	1)
Lamp Voltage	V _L	—	510	—	V _{rms}	4)
Frequency	f _L	50	—	70	kHz	2)
Starting Lamp Voltage	V _S	1350	—	—	V _{rms}	3)

Notes

- 1) Longer I_L causes the shorter life of a lamp CFL.
- 2) Frequency of power supply for a CFL may cause interference with HSYNC frequency and causes beat or flicker on the display. Therefore, lamp frequency shall be as different as possible from HSYNC frequency in order to avoid the interference.
- 3) Ta = 0 °C
- 4) Lamp Voltage is measured as below.

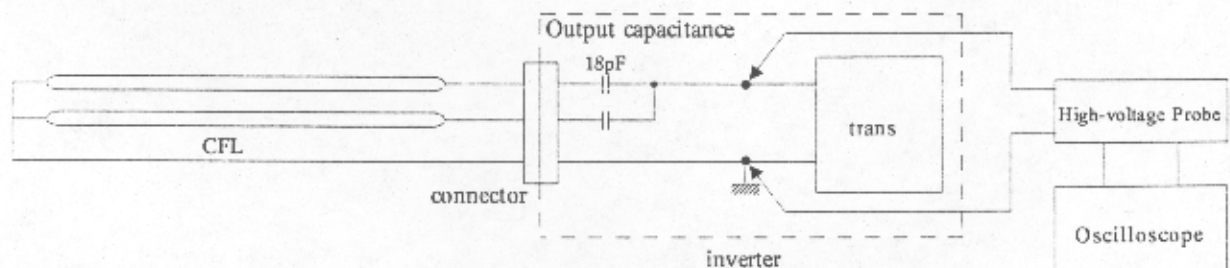

4. BLOCK DIAGRAM

4.1 TFT-LCD MODULE

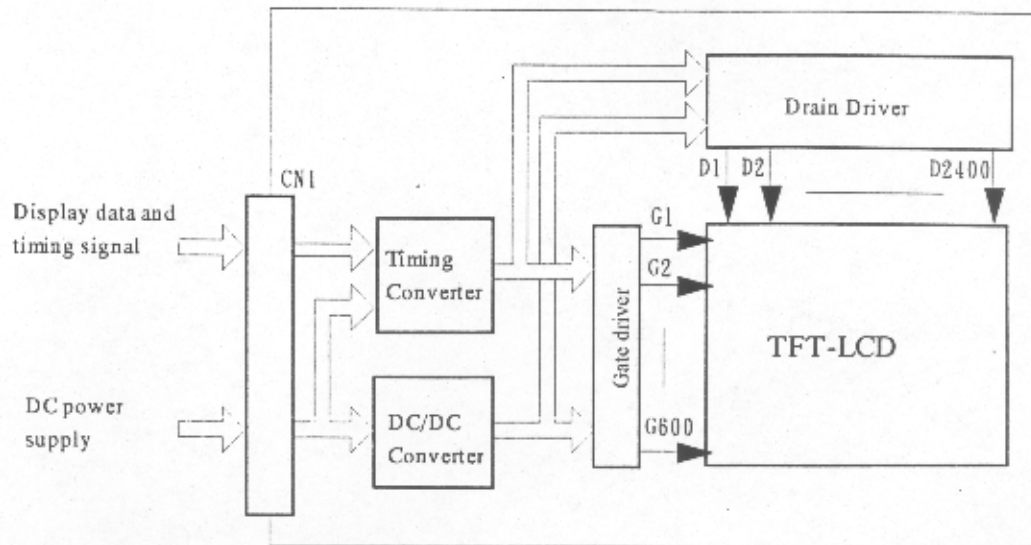

4.2 BACK-LIGHT UNIT

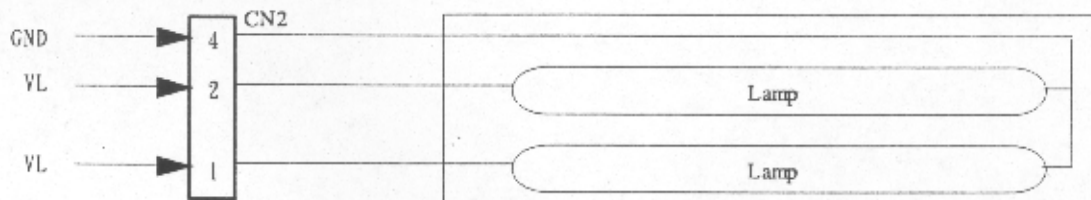

Color of wires from CFL to CN2

- 4 (GND) : White
- 1, 2 (VL) : Pink

5. INTERFACE PIN CONNECTION

5.1 TFT-LCD MODULE

CN1 《HIROSE ; DF9B-41P-1V or Equivalent》

Pin No.	Symbol	Description	Note
1	VSS	GND (0V)	1)
2	DCLK	Dot Clock	
3	VSS	GND (0V)	1)
4	Hsync	Horizontal Synchronization	
5	Vsync	Vertical Synchronization	
6	VSS	GND (0V)	1)
7	VSS		
8	VSS		
9	R0	Red Data	
10	R1		
11	R2		
12	VSS	GND (0V)	1)
13	R3	Red Data	
14	R4		
15	R5		
16	VSS	GND (0V)	1)
17	VSS		
18	VSS		
19	G0	Green Data	
20	G1		
21	G2		
22	VSS	GND (0V)	1)
23	G3	Green Data	
24	G4		
25	G5		
26	VSS	GND (0V)	1)
27	VSS		
28	VSS		
29	B0	Blue Data	
30	B1		
31	B2		
32	VSS	GND (0V)	1)
33	B3	Blue Data	
34	B4		
35	B5		
36	VSS	GND (0V)	1)
37	DTMG	Display Timing	
38	(NC)	Non-Connect	
39	VDD	Power Supply (typ.+3.3V)	2)
40	VDD		
41	(IC)		3)

- Notes
- 1) All VSS pins shall be grounded. Metal bezel is internally connected to VSS.
 - 2) All VDD pins shall be connected to +3.3V(Typ.).
 - 3) Keep open. Hitachi test use only.

5.2 BACK-LIGHT UNIT

CN2 《J.S.T. ; BHR-04VS-1》

Mating connector: SM03(7-D1)B-BHS-1 (J.S.T.)

Pin No.	Symbol	Description	Note
1	VL	Power Supply	
2	VL	Power Supply	
3	NC	No connection	
4	GND	GND(0V)	

5.3 RELATIONSHIP BETWEEN DISPLAYED COLOR AND INPUT DATA

Color	Input	Red Data						Green Data						Blue Data					
		R5	R4	R3	R2	R1	R0	G5	G4	G3	G2	G1	G0	B5	B4	B3	B2	B1	B0
		MSB			LSB			MSB			LSB			MSB			LSB		
Basic Color	Black	0	0	0	0	0	0	0	0	0	0	0	0	0	0	0	0	0	0
	Red (0)	1	1	1	1	1	1	0	0	0	0	0	0	0	0	0	0	0	0
	Green (0)	0	0	0	0	0	0	1	1	1	1	1	1	0	0	0	0	0	0
	Blue (0)	0	0	0	0	0	0	0	0	0	0	0	0	1	1	1	1	1	1
	Cyan	0	0	0	0	0	0	1	1	1	1	1	1	1	1	1	1	1	1
	Magenta	1	1	1	1	1	1	0	0	0	0	0	0	1	1	1	1	1	1
	Yellow	1	1	1	1	1	1	1	1	1	1	1	1	0	0	0	0	0	0
	White	1	1	1	1	1	1	1	1	1	1	1	1	1	1	1	1	1	1
Red	Black	0	0	0	0	0	0	0	0	0	0	0	0	0	0	0	0	0	0
	Red (62)	0	0	0	0	0	1	0	0	0	0	0	0	0	0	0	0	0	0
	Red (61)	0	0	0	0	1	0	0	0	0	0	0	0	0	0	0	0	0	0
	:	:	:	:	:	:	:	:	:	:	:	:	:	:	:	:	:	:	:
	:	:	:	:	:	:	:	:	:	:	:	:	:	:	:	:	:	:	:
	Red (2)	1	1	1	1	0	1	0	0	0	0	0	0	0	0	0	0	0	0
	Red (1)	1	1	1	1	1	0	0	0	0	0	0	0	0	0	0	0	0	0
	Red (0)	1	1	1	1	1	1	0	0	0	0	0	0	0	0	0	0	0	0
Green	Black	0	0	0	0	0	0	0	0	0	0	0	0	0	0	0	0	0	0
	Green (62)	0	0	0	0	0	0	0	0	0	0	0	1	0	0	0	0	0	0
	Green (61)	0	0	0	0	0	0	0	0	0	0	1	0	0	0	0	0	0	0
	:	:	:	:	:	:	:	:	:	:	:	:	:	:	:	:	:	:	:
	:	:	:	:	:	:	:	:	:	:	:	:	:	:	:	:	:	:	:
	Green (2)	0	0	0	0	0	0	1	1	1	1	0	1	0	0	0	0	0	0
	Green (1)	0	0	0	0	0	0	1	1	1	1	1	0	0	0	0	0	0	0
	Green (0)	0	0	0	0	0	0	1	1	1	1	1	1	0	0	0	0	0	0
Blue	Black	0	0	0	0	0	0	0	0	0	0	0	0	0	0	0	0	0	0
	Blue (62)	0	0	0	0	0	0	0	0	0	0	0	0	0	0	0	0	0	1
	Blue (61)	0	0	0	0	0	0	0	0	0	0	0	0	0	0	0	0	1	0
	:	:	:	:	:	:	:	:	:	:	:	:	:	:	:	:	:	:	:
	:	:	:	:	:	:	:	:	:	:	:	:	:	:	:	:	:	:	:
	Blue (2)	0	0	0	0	0	0	0	0	0	0	0	0	1	1	1	1	0	1
	Blue (1)	0	0	0	0	0	0	0	0	0	0	0	0	1	1	1	1	1	0
	Blue (0)	0	0	0	0	0	0	0	0	0	0	0	0	1	1	1	1	1	1

Notes 1) Definition of gray scale:

Color(n) Number in parenthesis indicates gray scale level. Lower n corresponds to brighter level.

2) Data: 1:High, 0:Low

6. INTERFACE TIMING

6.1 TIMING CHART

(Data : Latched at Fall edge of DCLK)

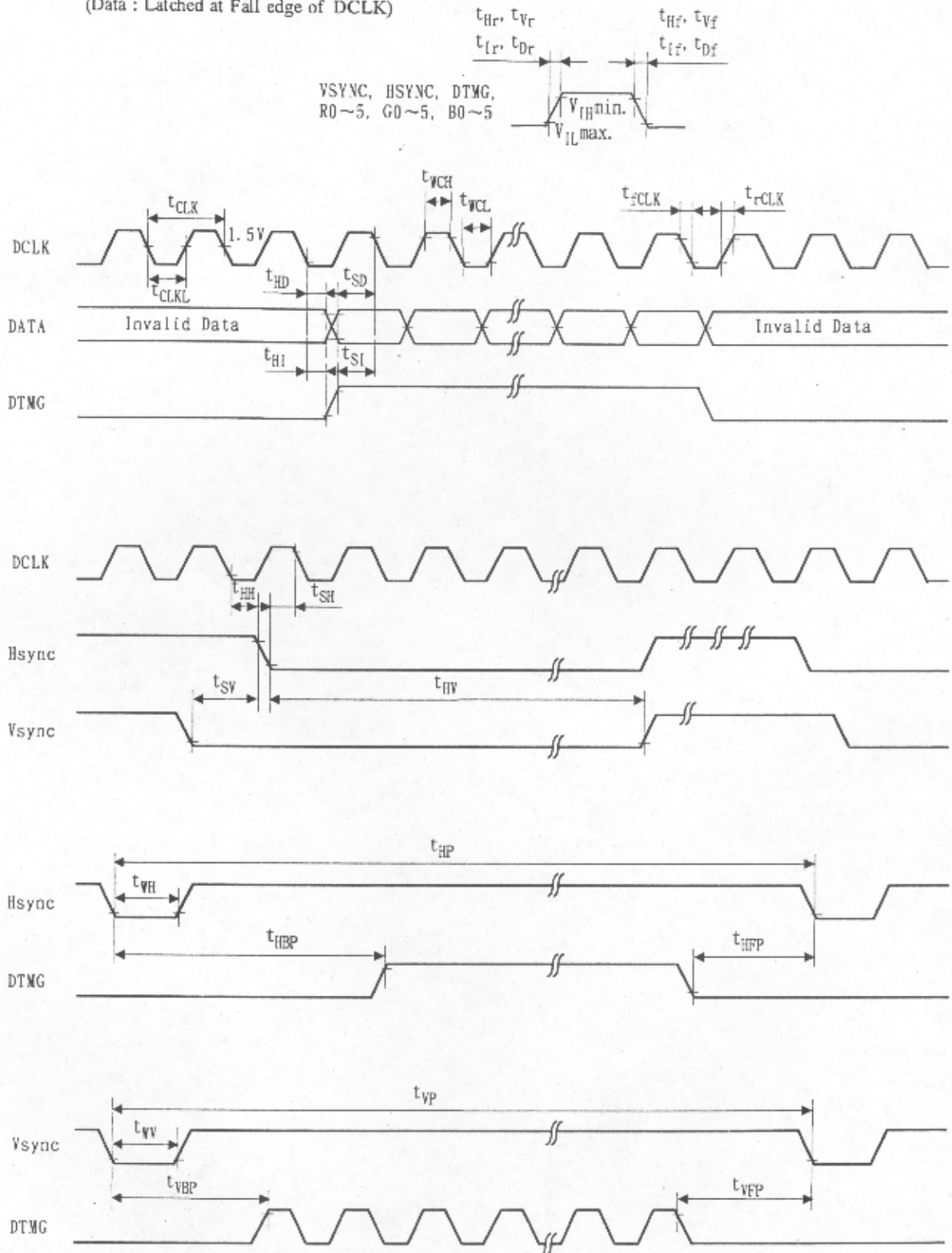

6.2 INTERFACE TIMING SPECIFICATIONS

Item		Symbol	Min.	Typ.	Max.	Unit	Note
DCLK	Period	t_{CLK}	25	26	—	ns	
	Width-Low	t_{WCL}	8	—	—		
	Width-Hi	t_{WCH}	8	—	—		
	Rise Time	t_{rCLK}	—	—	25		
	Fall Time	t_{fCLK}	—	—	25		
	Duty	D	0.45	0.5	0.55	—	
Hsync	Set up Time	t_{SH}	6	—	—	ns	for DCLK
	Hold Time	t_{HH}	6	—	—		
	Period	t_{HP}	$1052 - t_{HBP}$	1024	1200	t_{CLK}	
	Width-Active	t_{WH}	8	—	120		
	Rise/Fall Time	t_{Hr}, t_{Hf}	—	—	30	ns	
Vsync	Set up Time	t_{SV}	0	—	—	t_{CLK}	for Hsync
	Hold Time	t_{HV}	2	—	—		
	Period	t_{VP}	603	625	1000	t_{HP}	
	Width-Active	t_{VW}	1	—	24		
	Rise/Fall Time	t_{Vr}, t_{Vf}	—	—	50	ns	
DTMG	Set up Time	t_{SI}	6	—	—	ns	for DCLK
	Hold Time	t_{HI}	6	—	—		
	Rise/Fall Time	t_{Ir}, t_{If}	—	—	30	ns	
	Horizontal Back porch	t_{HBP}	32	—	100	t_{CLK}	
	Horizontal Front porch	t_{HFP}	16	—	—		
	Vertical Back porch	t_{VBP}	0	—	—	t_{HP}	
	Vertical Front porch	t_{VFP}	3	—	—		
DATA	Set up Time	t_{SD}	6	—	—	ns	for DCLK
	Hold Time	t_{HD}	6	—	—		
	Rise/Fall Time	t_{Dr}, t_{Df}	—	—	25	ns	

6.3 TIMING BETWEEN INTERFACE SIGNAL AND POWER SUPPLY

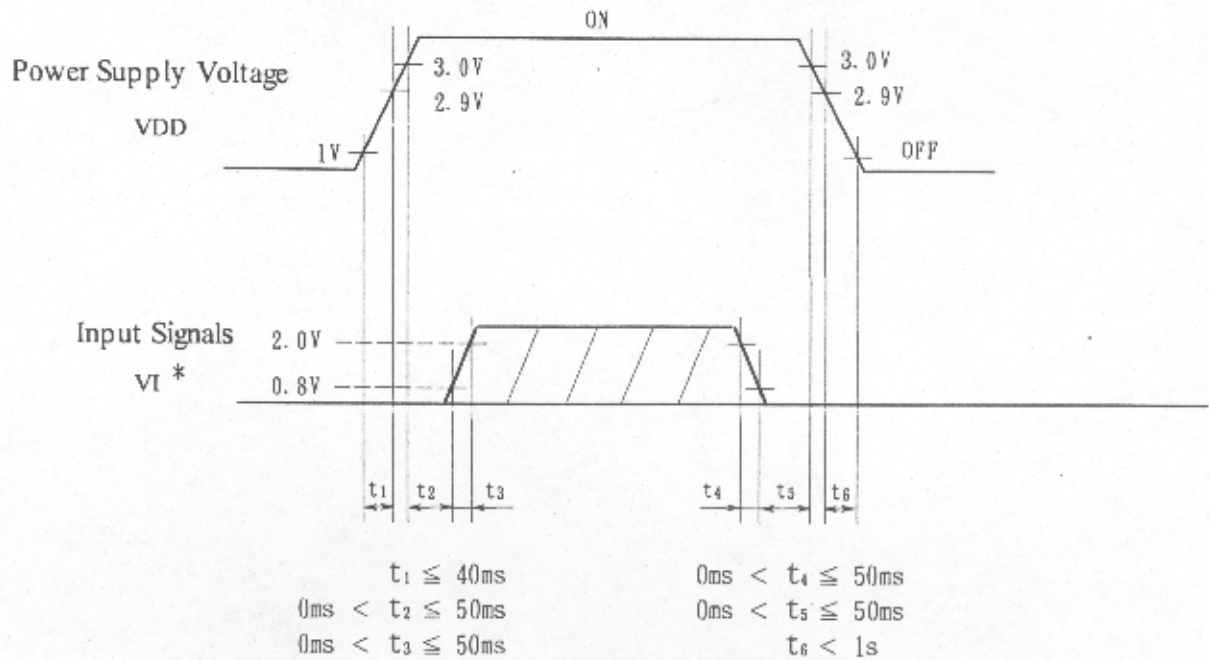

POWER ON OFF

* Set $0\text{V} \leq V_I(t) \leq V_{DD}(t)$.

Here, $V_I(t)$, $V_{DD}(t)$ indicate the transitive state of V_I , V_{DD} when power supply is turned ON or OFF.

Note 1) Do not keep interface signal high-impedance when power on.

7.DIMENSIONAL OUTLINE

(1)Front View

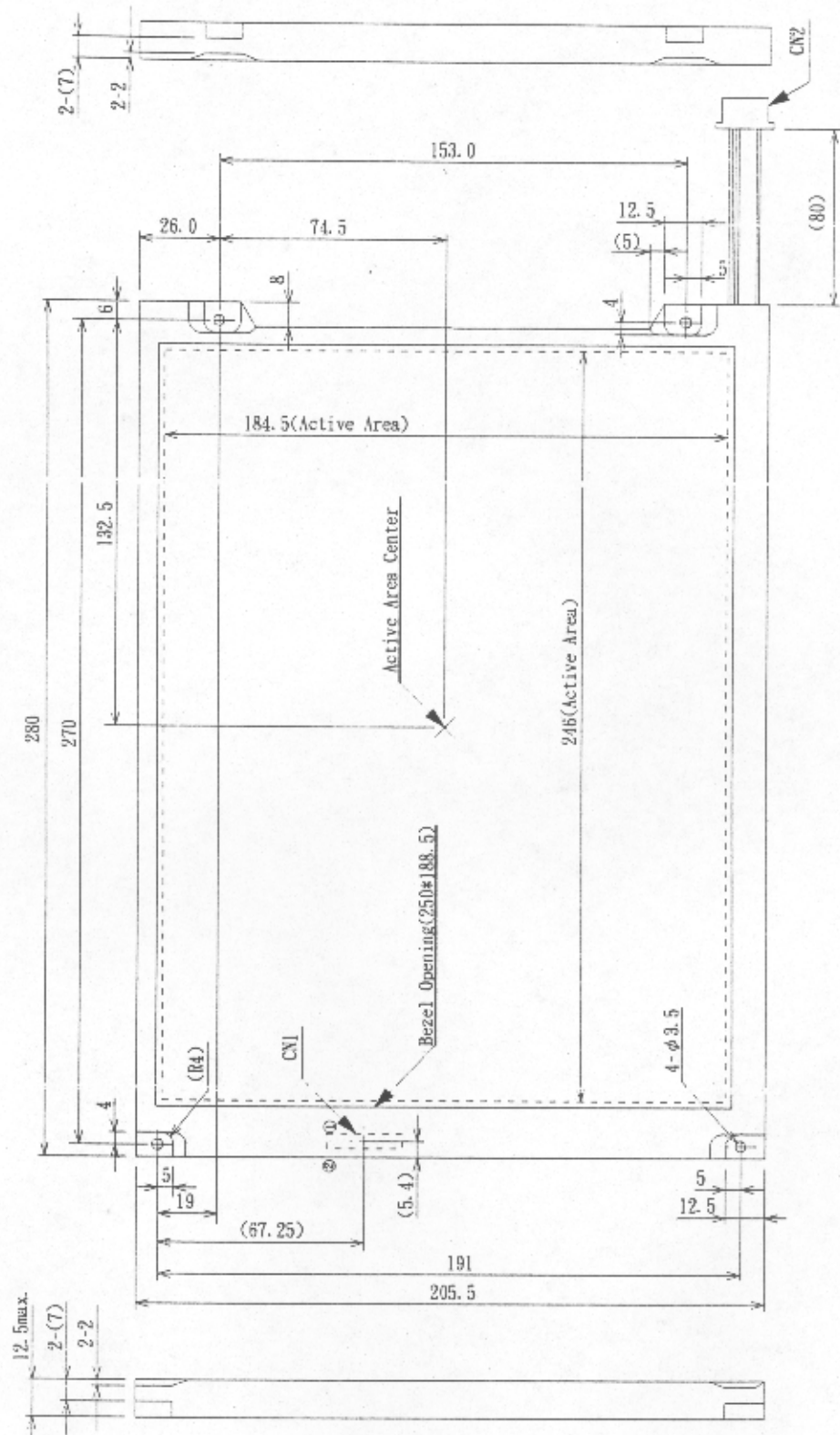

- Note
- 1)CN1 : HIROSE DF9B-41P-1V
 - 2)CN2 : JST BHR-04VS-1
 - 3)Tolerance in specified is ± 0.5 mm.
 - 4)Dimensions in parenthesis are reference value.

Unit:mm
Scale:NTS

Hitachi,Ltd	Date	Sep. 5,2000	Sheet No.	3284PS 2610-TX31D30VC1CAA-1	Page	10-1/2
-------------	------	-------------	-----------	-----------------------------	------	--------

(2)Back View

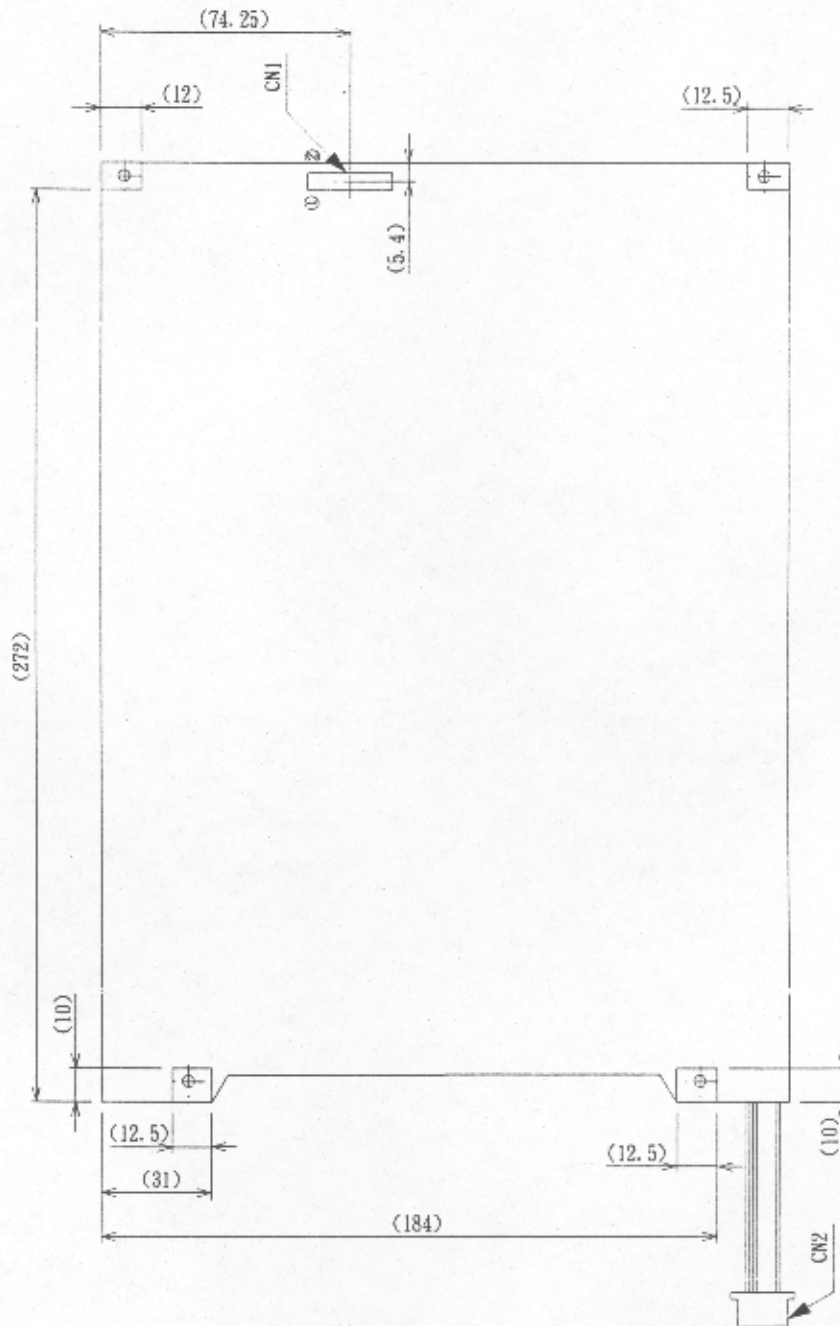

Unit:mm
Scale:NTS

Hitachi,Ltd	Date	Sep. 5,2000	Sheet No.	3284PS 2610-TX31D30VC1CAA-1	Page	10-2/2
-------------	------	-------------	-----------	-----------------------------	------	--------

8. DESIGNATION OF LOT MARK

8.1 LOT MARK

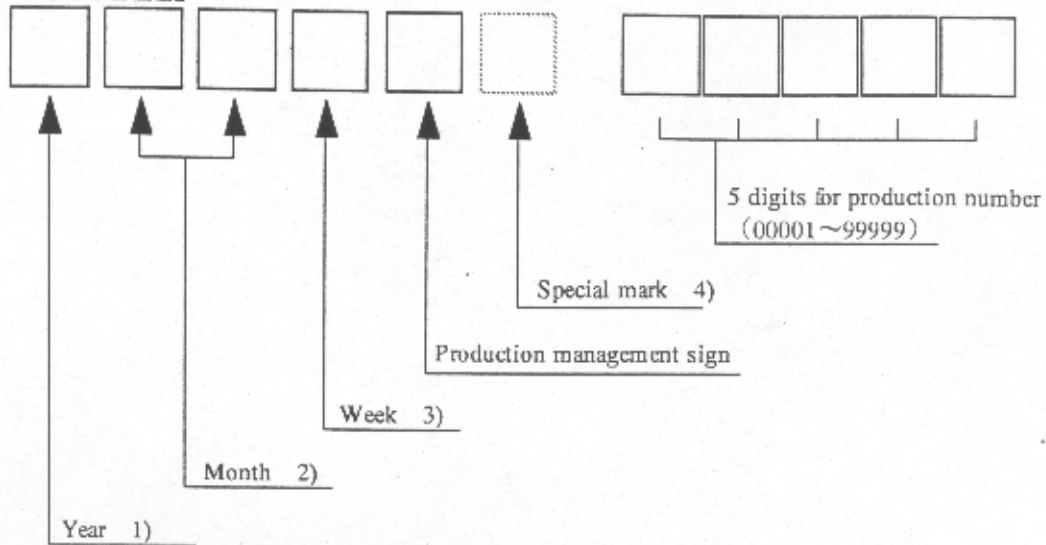

Notes

1)

Year	Mark
2000	0
2001	1
2002	2
2003	3
2004	4

2)

Month	Mark	Month	Mark
1	01	7	07
2	02	8	08
3	03	9	09
4	04	10	10
5	05	11	11
6	06	12	12

3)

Week (Days)	Mark
1~7	1
8~14	2
15~21	3
22~28	4
29~31	5

4) The special mark may be added by manufacturing accordingly to production number.

8.2 REVISION(REV.) CONTROL

REV. column is controlled by the manufacturing. A-Z except I and O is to be written on this column.

8.3 LOCATION OF LOT MARK

Lot mark is printed on a label. The label is on the metal bezel as shown in the drawing at Section 7.

The style of character may be changed without notice.



9. COSMETIC SPECIFICATIONS

9.1 VISUAL INSPECTION

(1) INSPECTED AREA

i) The distance between inspector's eyes and the module is around 300mm. Viewing angle for inspection is as follows.

$\theta \leq 45^\circ$ when non-operating inspection.

$\theta \leq 5^\circ$ when operating inspection.

ii) Inspection should be executed only from front side, and only for A-zone. The visual defects of B & C-zone are ignore.

(refer to 9.2 DEFINITION OF ZONE)

(2) ENVIRONMENTAL

i) Ambient temperature :25°C

ii) Illumination for inspection should be around 500[lx] in the module operation and around 1000[lx] in non-operation. It should be also non-directional.

iii) Back-light is powered on in the inspection for module operation.

(3) OPERATING INSPECTION

Number of display colors in the inspection is 8 only. (Gray scale 0 and 63 for each Red, Green, Blue, and White)

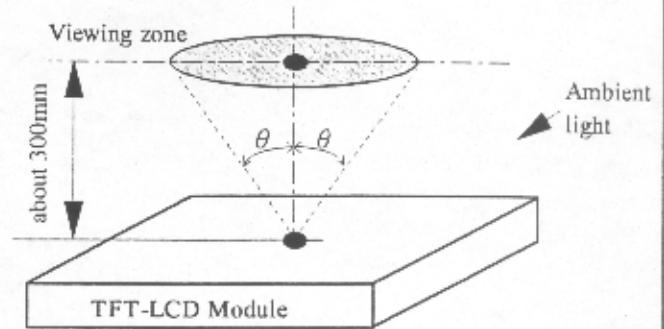

9.2 DEFINITION OF ZONE

Each zone is defined as follows. The visual defects is specified at A-zone and the specification is not applicable to B & C-zone. (Defects in B&C-zone are disregarded.)

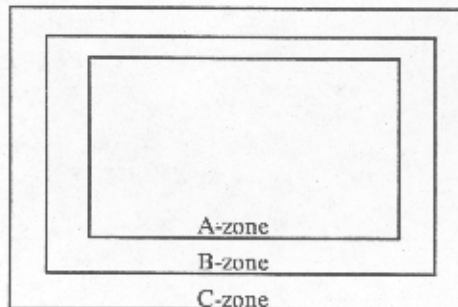

- A-zone: Display area (pixel area)
- B-zone: Area between A-zone and C-zone
- C-zone: Metallic bezel area (include I/F connector)

9.3 COSMETIC SPECIFICATION

The followings are inspected at the module stable operation and defects appearing at powered on & off is disregard.

	No.	ITEM		Maximum Acceptable Number		Note	
				A-zone	Unit		
Operating Inspection	1	Dot Defect	Sparkle Mode	1dot	5	pcs	1),2),4)
				2dot	2	unit	1),2),5)
				3dot	0		
				4dot	0		
				Density	3		
				Total	5	pcs	1),2)
			Black Mold	1dot	5	pcs	1),3),4)
				2dot	2	unit	1),3),5)
				3dot	0		
				4dot	0		
				Density	3	pcs/ ϕ 20mm	1),3),6)
	Total	5	pcs	1),3)			
	Total	10	pcs	1)			
	2	Line Defect			Serious one is not allowed.		-
	3	Uneven brightness			Serious one is not allowed.		-
	4	Stain Inclusion Line shape W:width(mm) L:length(mm)	$W \leq 0.02$	L:ignore	Ignore	pcs	7)
				$W \leq 0.03$	$L \leq 2.0$		
$W \leq 0.06$			$L > 2.0$		0		
			$L \leq 1.0$	10			
$L > 1.0$	0						
5	Stain Inclusion Dot shape D:average dia.(mm)	$D \leq 0.22$		Ignore	pcs	7)	
		$D \leq 0.33$		5			
		$D > 0.33$		0			
6	Scratch on polarizer Line shape W:width(mm) L:length(mm)	$W \leq 0.01$	L:ignore	Ignore	pcs	8)	
			$W \leq 0.02$	$L \leq 40$			10
		$W \leq 0.04$		$L > 40$			0
			$L \leq 20$	10			
$L > 20$	0						
7	Scratch on polarizer Dot shape D:average dia.(mm)	$D \leq 0.2$		Ignore	pcs	8)	
		$D \leq 0.4$		10			
		$D > 0.4$		0			

	No.	ITEM		Maximum Acceptable Number		Note
				A-zone	Unit	
Non-Operating Inspection	8	Bubbles, Peeling in Polarizer D: average dia. (mm)	$D \leq 0.3$	ignore	pcs	8)
			$D \leq 0.5$	10		
			$D \leq 1.0$	5		
			$D > 1.0$	0		
	9	Wrinkles on Polarizer	Serious one is not allowed.		-	-

- Notes
- 1) Defect whose area per each dot is over 50% is regarded as Dot Defect.
 - 2) Defect whose brightness at all black screen is more than 30% is regarded as Bright Dot Defect.
 - 3) Defect whose brightness at all white screen is less than 70% is regarded as Dark Dot Defect.
 - 4) Defect dots which are not adjacent are regarded as single Dot Defect each.
 - 5) 2 or more Adjacent Defect dots is regarded as n(number)-adjacent Dot Defect.
 - 6) Defect density is defined by the number of defects existing in the 20mm ϕ .
 - 7) Defect which can be easily wiped off is disregarded.
 - 8) The specification is applicable only to A-zone and if these defects are in B-zone, they are disregarded.
 - 9) In case of gray scale pattern, obvious defects is to be rejected.
 - 10) In case any problem which is not specified in this specification would be brought out both parties should discuss needed items such as limit sample, etc.

10. PRECAUTIONS

Please take care about the followings in handling the TFT Module.

10.1 PRECAUTIONS IN MOUNTING MODULE

- (1) Please do not give a stress on the module which cause damage on the metal, plastic, and LCD glass.
- (2) The module should be appropriately handled by both hands. Please never hold top and bottom side of the module by just one hand.
- (3) The module should be mounted into the enclosure by each mounting hole on the corner.
- (4) Please ensure the module not be stressed in being mounted.
- (5) Then the module should be placed around 1mm from inside of the enclosure as shown in Fig. 1.
To improve the strength of module against the mechanical shock the space between module and the case should be less than 1.0mm.

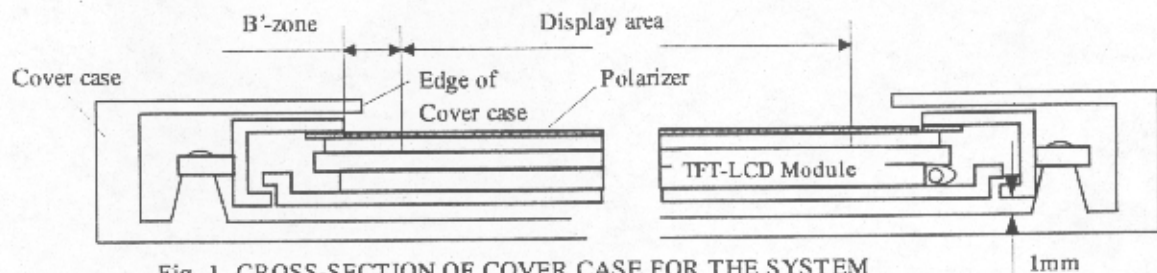
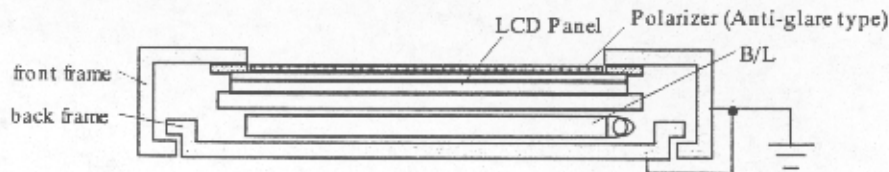

Fig. 1 CROSS-SECTION OF COVER CASE FOR THE SYSTEM

- (6) The edge of the front plastic window should be within the B'-zone' shown in Fig.1 by more than 1 mm from the metal frame window of the module.
- (7) It is preferable to place a transparent plate on the display area in order to protect the polarizer and LCD glass. The plate should be placed away from the surface of the module.
- (8) Please do not use acetic acid & chlorine type materials for enclosure & other components surrounding the module since these materials give rise to the gas at high temperature which degrade the polarizer and cause open circuit at the module electrical circuit due to electro-chemical reaction.
- (9) Polarizer is easily scratched and should be carefully handled then. Please do not touch, push, and rub the polarizer by hard materials such as glass, tweezers and others harder than HB pencil lead. Also, please do not touch it by bare-hand.
- (10) In case of cleaning the polarizer, please wipe it with absorbent cotton, chamois or other soft materials absorbing Normal-Hexane recommended as cleaning chemicals.
- (11) Saliva and water drop should be immediately wiped off since they degrade the polarizer.
- (12) Please do not disassemble and modify the module yourselves since it may malfunction.
- (13) Metal frame should not be touched with bare-hand and dirty gloves since it may be degraded.
- (14) The module rear side should not be touched with metal in being mounted.
- (15) Please do not pull and hold the lamp cable.

10.2 PRECAUTIONS IN OPERATION OF MODULE

- (1) The module is heated by the backlight in operation. The module needs to be appropriately being cooled in order to avoid brightness reduction so that the ambient temperature would be within the specifications.
- (2) Spike noise from the power supply may cause functional error and damage the module.
Overshooting & undershooting of VDD voltage should be within +/- 200 mV under the maximum rating.
- (3) Optical performance of the TFT-LCD changes by the temperature. (Response time gets longer at lower temperature.)
- (4) Lamp start-up time also gets longer at lower temperature.
- (5) In case that environmental temperature suddenly changes, it may cause the condensation and dew on the module.
Please be careful so that the condensation would not happen since it cause the degrade of optical performance and malfunction.
- (6) Image sticking may happen after the same pattern being displayed for long time but it will disappear soon.
Please do not display the same pattern for long time so as not to bring about image sticking.
- (7) Please ensure the countermeasures for electro-magnetic interference which affect the electrical circuit of the module.
Grounding & shielding method is effective to reduce the radiation.
- (8) Acoustic noise may happen in the backlight operation. If necessary, please take appropriate countermeasures.
- (9) In case the lamp cable is made longer, it may cause brightness drop and degrade lamp start-up.
It is preferable to connect it directly to CFL inverter.
- (10) Please do not connect and remove the module while a main system is powered on.
- (11) Grounding the metal of the module is preferable to prevent the video from flickering and rolling.



10.3 ELECTRO-STATIC DISCHARGE CONTROL

- (1) The module is easily damaged when it suffers from electro-static discharge over the specification.
Please take care about the control such as grounding human body in handling the module. Also, please do not touch the connector with bare-hand.
- (2) Protection film on polarizer should be slowly removed so that electro-static discharge could be reduced.

10.4 PRECAUTIONS FOR LIGHT EXPOSURE

- (1) Please do not expose the module against the intensive light which is likely to degrade the polarizer & color filter.

10.5 PRECAUTIONS IN STORAGE OF MODULE

In case of long term storage of the module, the followings should be taken care about.

- (1) The module should be stored in a dark with appropriate humidity (60 % RH or below) at 5 to 35 °C.
- (2) Nothing should contact on the polarizer while the module being stored. It is preferable to store the modules in the packaging of the shipment.

10.6 PRECAUTIONS IN HANDLING PROTECTION FILM

- (1) The protection film on polarizer should be slowly removed with wrist band grounded so as to reduce electro-static discharge. Ionized air blow is also effective.
- (2) In case the polarizer is rubbed by the protection film while being removed, the adhesive on the film may remain on the polarizer. Then, please be careful not to rub the polarizer while removing the protection film.
- (3) Please take care about the storage condition in case of remaining the protection film on the polarizer.
The adhesive on the film may move onto the polarizer at high temperature & high humidity.
- (4) The adhesive remaining on the polarizer should be wiped off with absorbent cotton absorbing Normal Hexane.

10.7 SAFETY

- (1) The module is unit which consists of LCD glass and backlight. In case of being dropped and mechanically shocked, it may be cracked. Please take care about the cracked glass. In addition, hands should be washed if you touch the liquid material from the broken LCD.
- (2) Electrically conductive materials should be never put into the module. Backlight unit generates especially high voltage and you should take care about it.
- (3) The CFL inverter should be designed to include the function of output shutdown in case the output overcurrent happen due to any backlight trouble.
The shutdown function should be assured to work in abnormal condition at the actual systems.

10.8 ECOLOGY

- (1) The lamp of backlight has a little mercury. Please handle it appropriately in case of disposal.
- (2) Flex cable and Printed Wire Board have a little lead. Then, please handle them appropriately in case of disposal.

10.9 USE RESTRICTIONS AND LIMITATIONS

- (1) This product is not authorized for use in life support devices or systems, military applications, or other applications which pose a significant risk of personal injury. Therefore, the product shall not be used for such purposes.
- (2) In no event shall Hitachi, Ltd., be liable for any incidental, indirect, or consequential damages in connection with the installation or use of this product, even if informed of the possibility thereof in advance. These limitations apply to all causes of action in the aggregate, including without limitation breach of contract, breach of warranty, negligence, strict liability, misrepresentation and other torts.

10.10 OTHERS

- (1) Electrical components which does not affect the module electrical performance may be changed without notice because of availability, etc.